

# FUTURE SOLUTIONS IN SMART STORAGE AND LOGISTICS

**ProdeUSA**  
Warehouse Solutions

**SMART WAREHOUSES**

**BREAKING BOUNDARIES**

Clever Steps in  
Optimizing  
Storage Solutions

 **Prode**  
Design Engineering

**T-Pick**  
Automatic Picking System

[www.usaprode.com](http://www.usaprode.com)

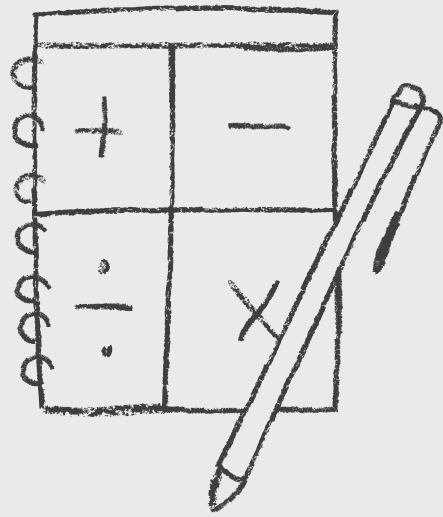

# SMART WAREHOUSES

## “Meet the Warehouse Solutions of the Future”

In today's world of rapidly evolving e-commerce, an effective warehouse management and logistics infrastructure is one of the key factors for success. By understanding our customers' needs, we offer solutions that optimize operations, increase efficiency and enable highly accurate and reliable deliveries. With our experience in setting up e-commerce and logistics warehouses, we aim for operational excellence while supporting the continued growth of our business partners. With smart warehouse technologies, strategic deployment plans and flexible logistics solutions, we take your business into the future. We are here to increase your efficiency and maximize your customer satisfaction with tailor-made warehouse applications for your needs.

**The right address for dependability, speed and performance**

## DESIGN

“We offer solutions that will maximize the use of space and expedite your workflow through warehouse designs. While increasing operational efficiency with both functional and flexible layout plans, we ensure that you utilize your workforce in the most productive way.”

## MANUFACTURING

“We produce durable and functionally optimized warehouse solutions with high quality materials and modern production know-how. We ensure that your operations run smoothly and efficiently with racking systems and logistics equipment customized for your needs.”

## SOFTWARE

“We improve operational capacities by digitalizing operations. With smart software solutions, we facilitate inventory tracking, accelerate order processing and minimize the margin of error. Get stronger with state-of-the-art technology to gain a competitive advantage in e-commerce and logistics.”



**MODERN  
WAREHOUSES**

**TRACEABLE**

**LOGISTICS OPERATIONS**

**WITH PRODE SMART WAREHOUSE SYSTEMS**

- Maximum efficiency is achieved with minimized labor force.
- Sector-specific warehouses are designed and a completely autonomous running is provided.
- Operational traceability is enhanced.
- All required reporting is done automatically
- Reports are created daily, monthly, annually or at designated intervals by supporting the operation with visualizations and statistics.

# EXTENDED REACH

“We transcend borders with our logistics and warehousing solutions in every country and on every continent around the world. With our global experience and extensive network, we make your operations efficient and robust around the world. We support you to grow your business on a global scale with our strategic logistics planning and flexible warehousing systems that adapt to the realities of each region.”

“We are the right address for fast delivery, smart warehousing and flawless logistics in your global operations.”

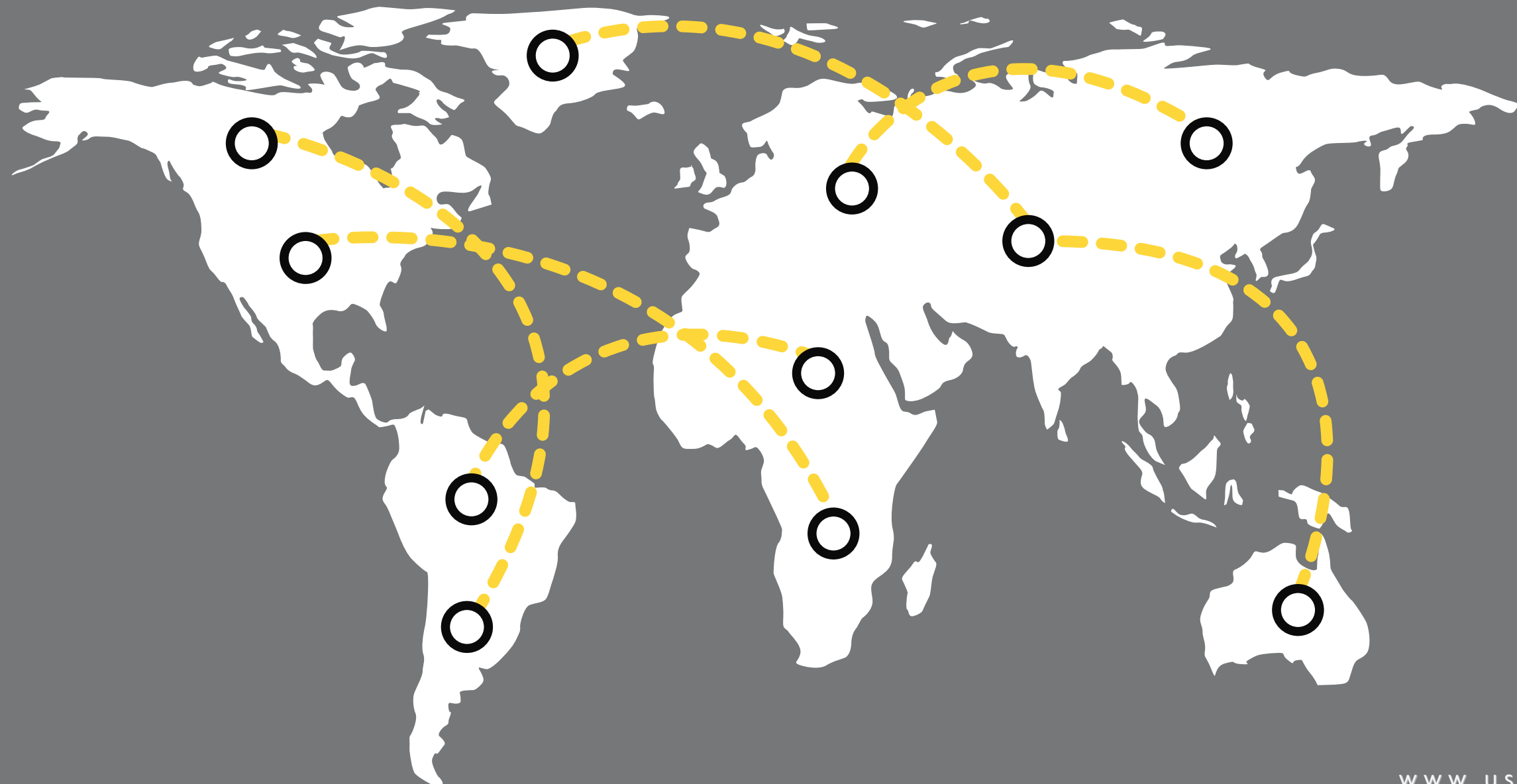

# RELIABLE and RESPONSIVE

**T-Pick**  
Automatic Picking System

- Reduces operational costs.
- Contributes to reduce carbon footprint.
- Full integration with customer ERP system is provided.
- Maximum protection against cyber attacks.
- PLC unit and all data gets backed up automatically against natural disasters. Data will not be lost in case of any kind of unfortunate event.

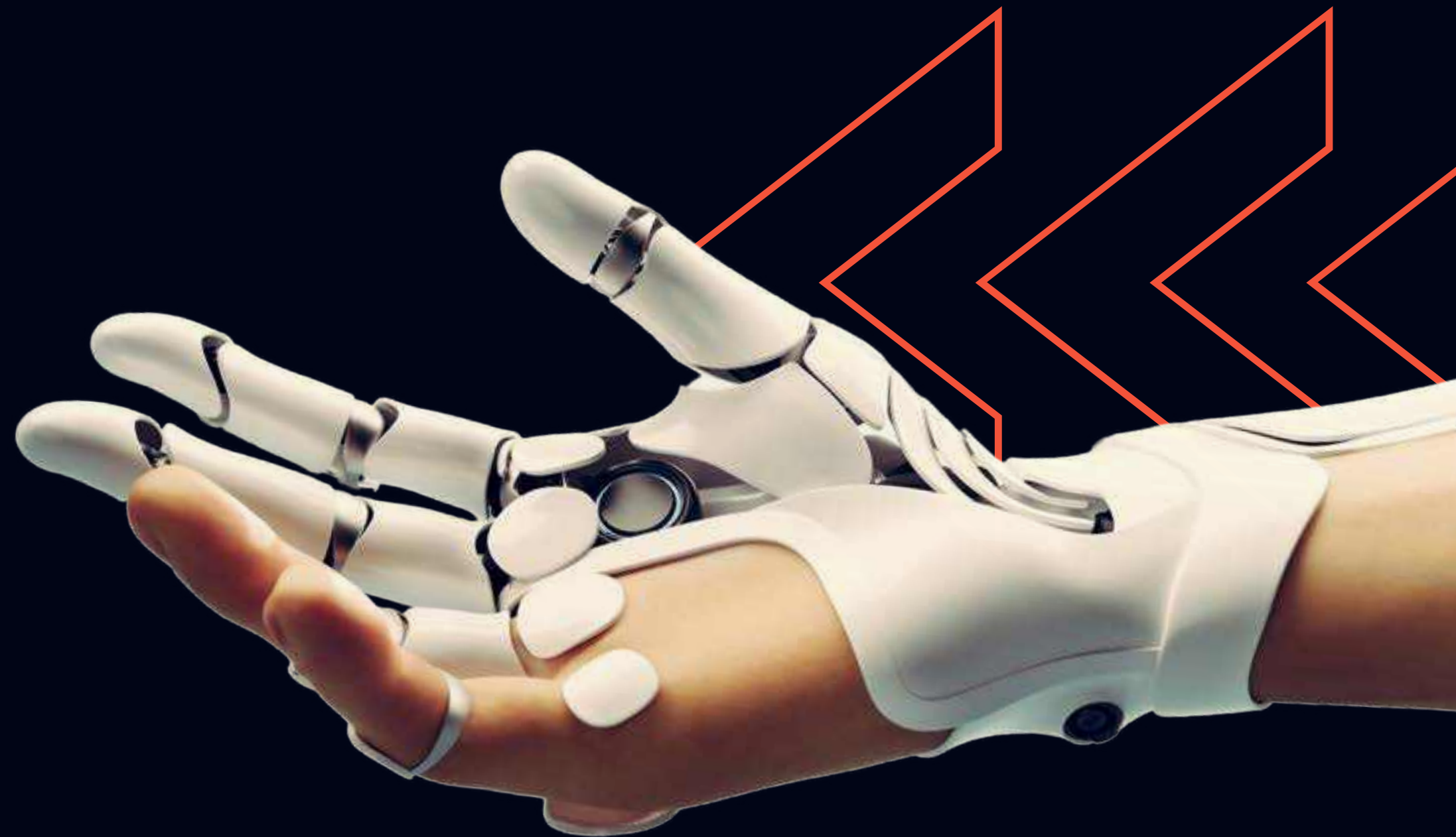

# T-PICK AUTOMATIC PICKING SYSTEM

**ProdeUSA**  
Warehouse Solutions

The fully self-operating T-Pick Automated Picking System has a picking capacity of 1800 orders per hour. If we assume that each order contains an average of 25 products, we conclude that it can collect an average of 45,000 products per hour.

It performs in an hour what 30 employees would achieve in a day, without using labor for collection.





1.

Only 2 employees are assigned to feed the products into the magazines. If requested, product feeding can also be designed to work in an automated way.

2.

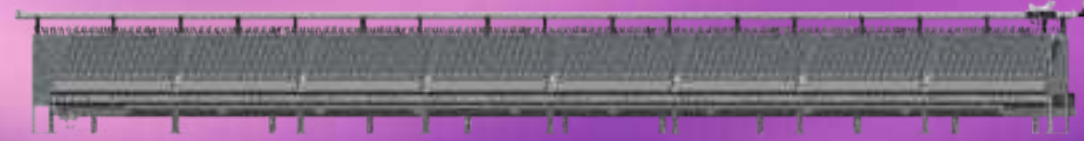

It is an essential item for dark warehouses.

3.

“Smart Logistics with the Power of Industry 4.0”

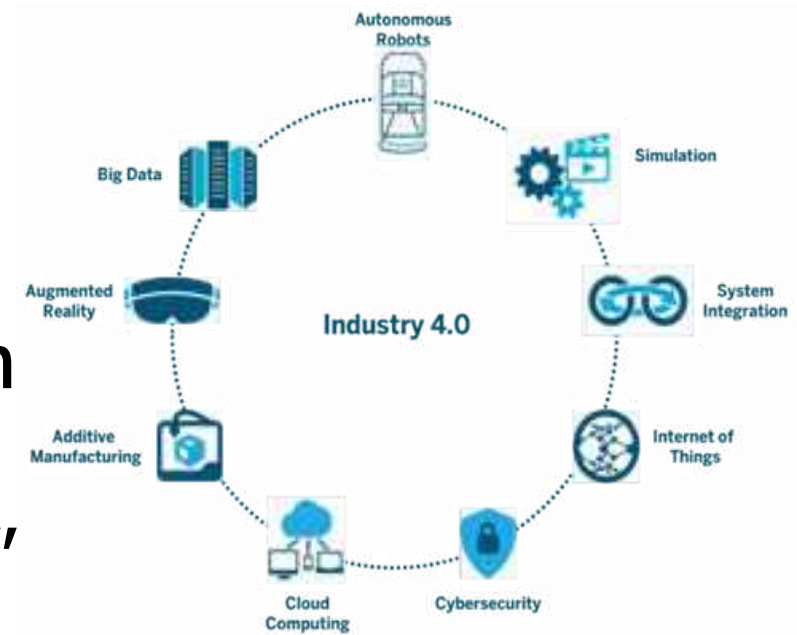

# T-PICK



- It can be used without any difficulties in the picking process of all products with containers such as cosmetics, pharmaceuticals, health sector and similar goods.

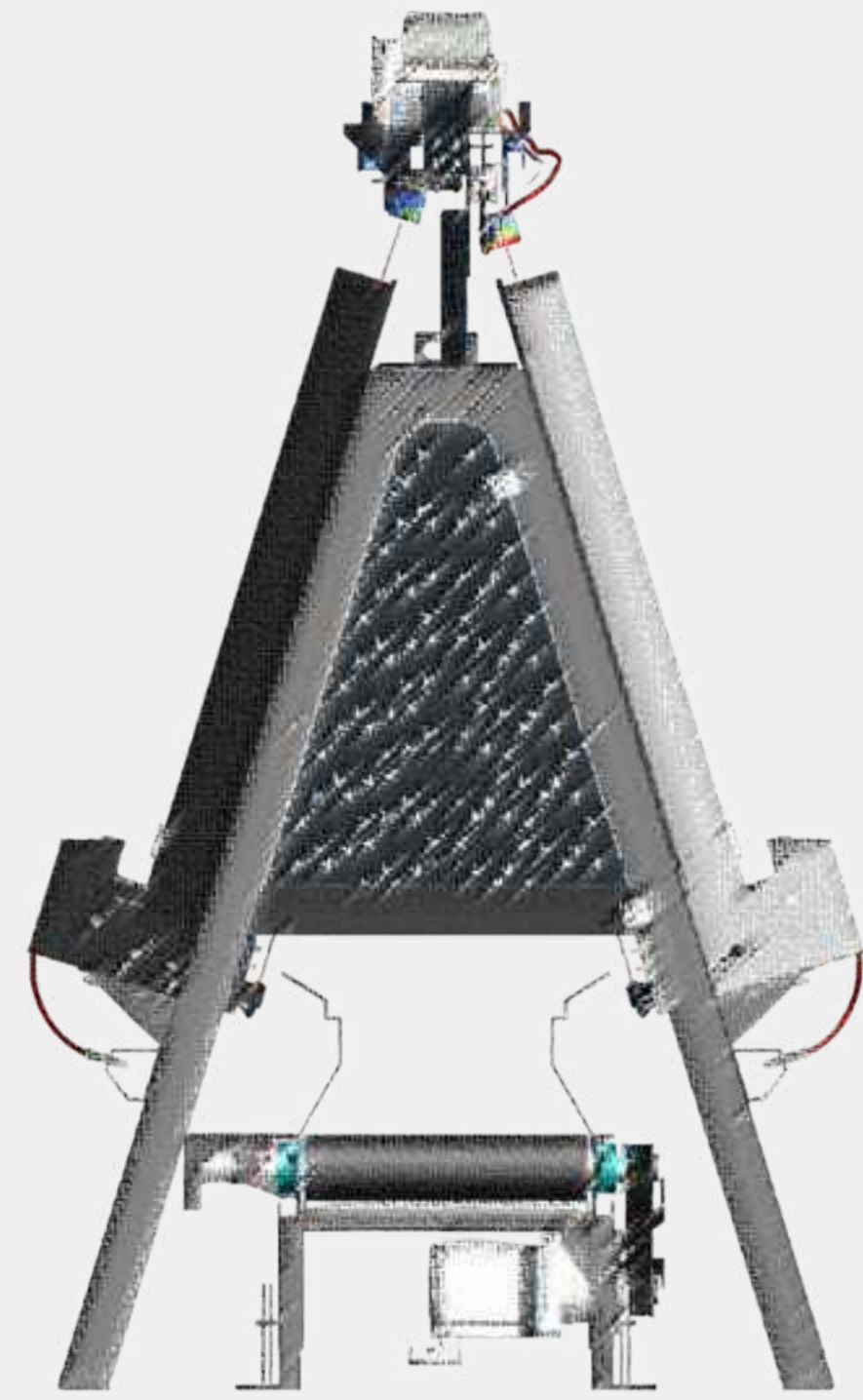

- Order error rate is close to zero.
- Lowers operational costs.
- Keeps the traceability of the operation at maximum level.





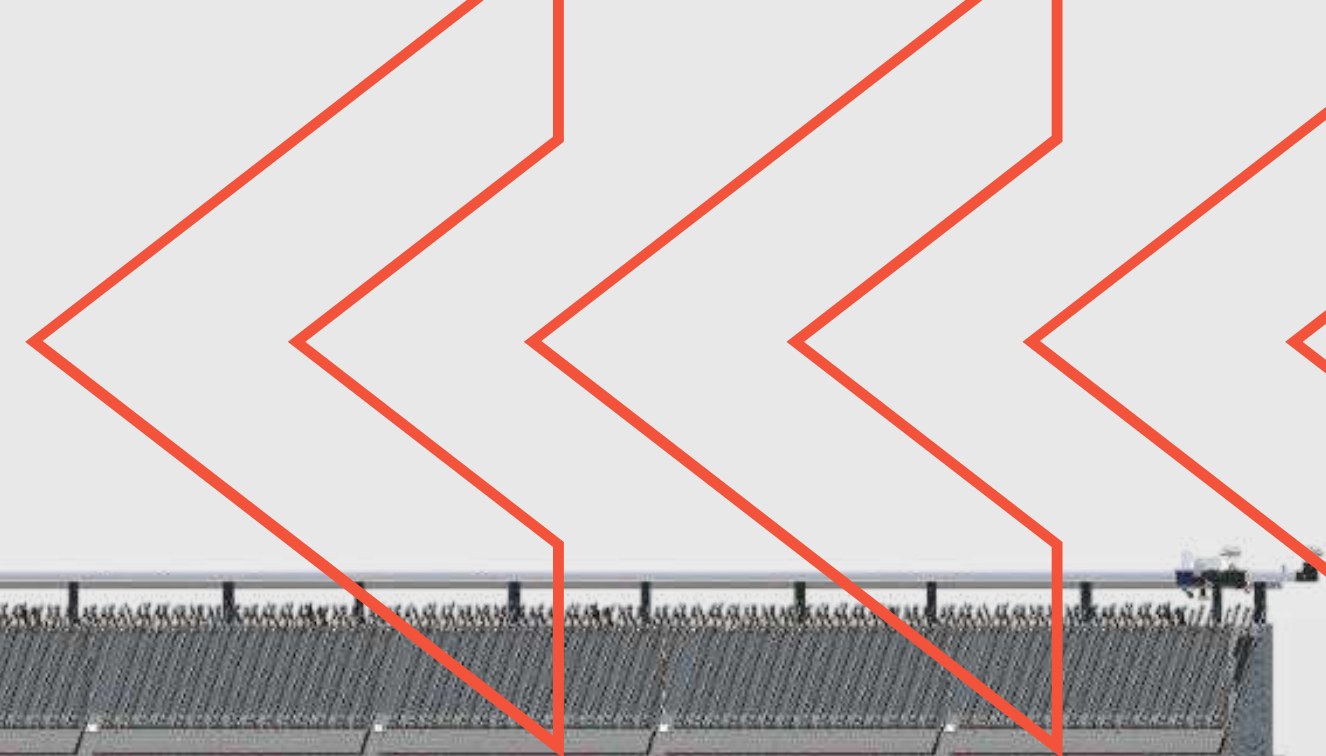

**T-PICK IS A FULLY AUTOMATED ORDER PICKING SOLUTION FOR RAPID COMMISSIONING OF SOPHISTICATED ORDERS. THIS FIELD-PROVEN TECHNOLOGY IS ALREADY BEING USED, AMONG OTHER APPLICATIONS, IN THE DISTRIBUTION OF PHARMACEUTICALS.**

The T-Pick guarantees the highest possible output and optimum material flow, even at peak loads. It performs excellently on high-volume orders of small, fast-moving products with comparable edged packaging. Examples include pharmacy boxes, personal healthcare products, tobacco and small office supplies as well.

Prode's T-Pick is characterized by a high degree of flexibility; the product magazines are adjustable. Intelligent ejectors ensure fully automatic, safe and optimized handling of the product.



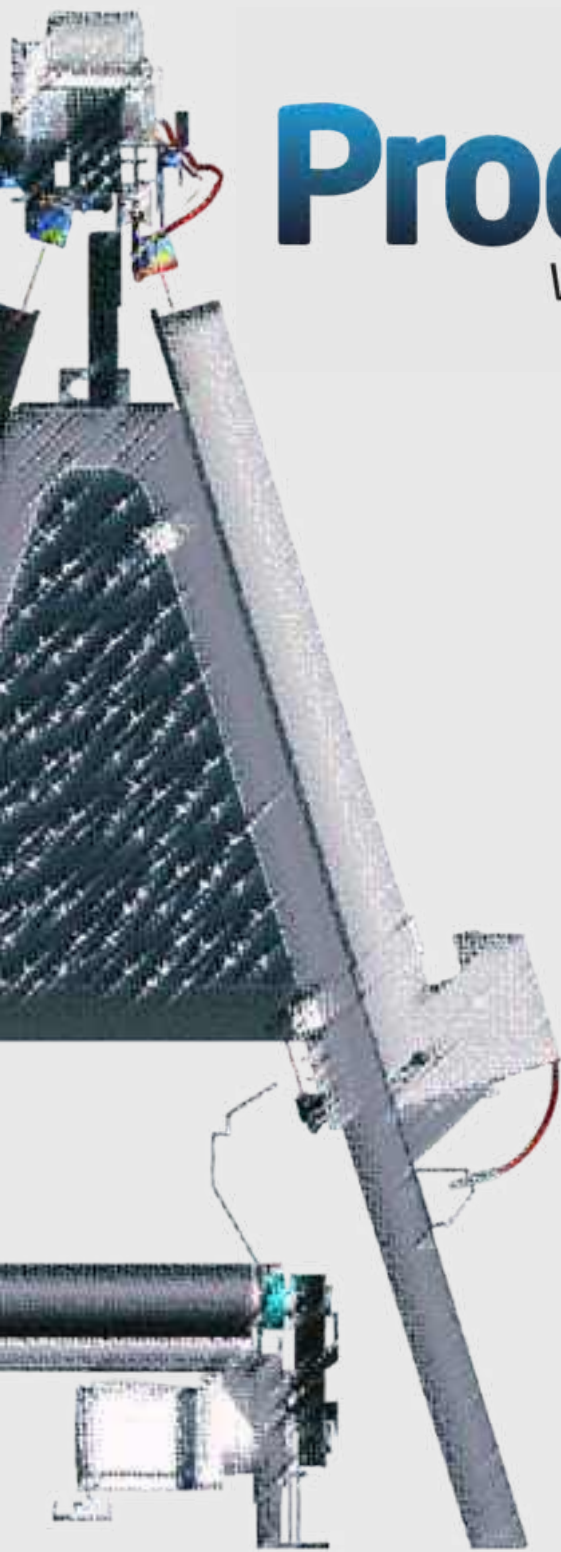

**ProdeUSA**  
Warehouse Solutions

# PICK

Automatic Picking System

**Prode**  
Design Engineering

- **FAST HANDLING OF COMPLEX ORDERS**
- **MODULAR DESIGN**
- **INTUITIVE USER INTERFACE**
- **LIVE VIDEO RECORDING**
- **FAST INSTALLATION/COMMISSIONING TIME**
- **DIFFERENTIATED ORDER PICKING**
- **ADJUSTABLE EJECTOR MAGAZINES ALLOW PRODUCTS OF VARIOUS SIZES TO FIT**
- **INTEGRATED BATCH TRACKING AND ACTIVE STOCK CONTROL BY PUMA**

# PUMA

Puma is an optional measuring device on top of the T-Pick. It calculates the height of the stacked products in the magazine and thereby the number of products, based on the loading quantity and the configuration of the products. This keeps the number of refill errors low.

1

## Video Recording

With live video recording at the end of T-Pick, orders and operation flow can be easily monitored administratively in physical reality.

2

## Aerial Mapping

Visualization of the use of products in the T-Pick enables the user to correctly distribute and spread the collected products on the T-Pick

3

## Modularity

T-Pick's add-ons are very simple, so installation and commissioning time is minimized.

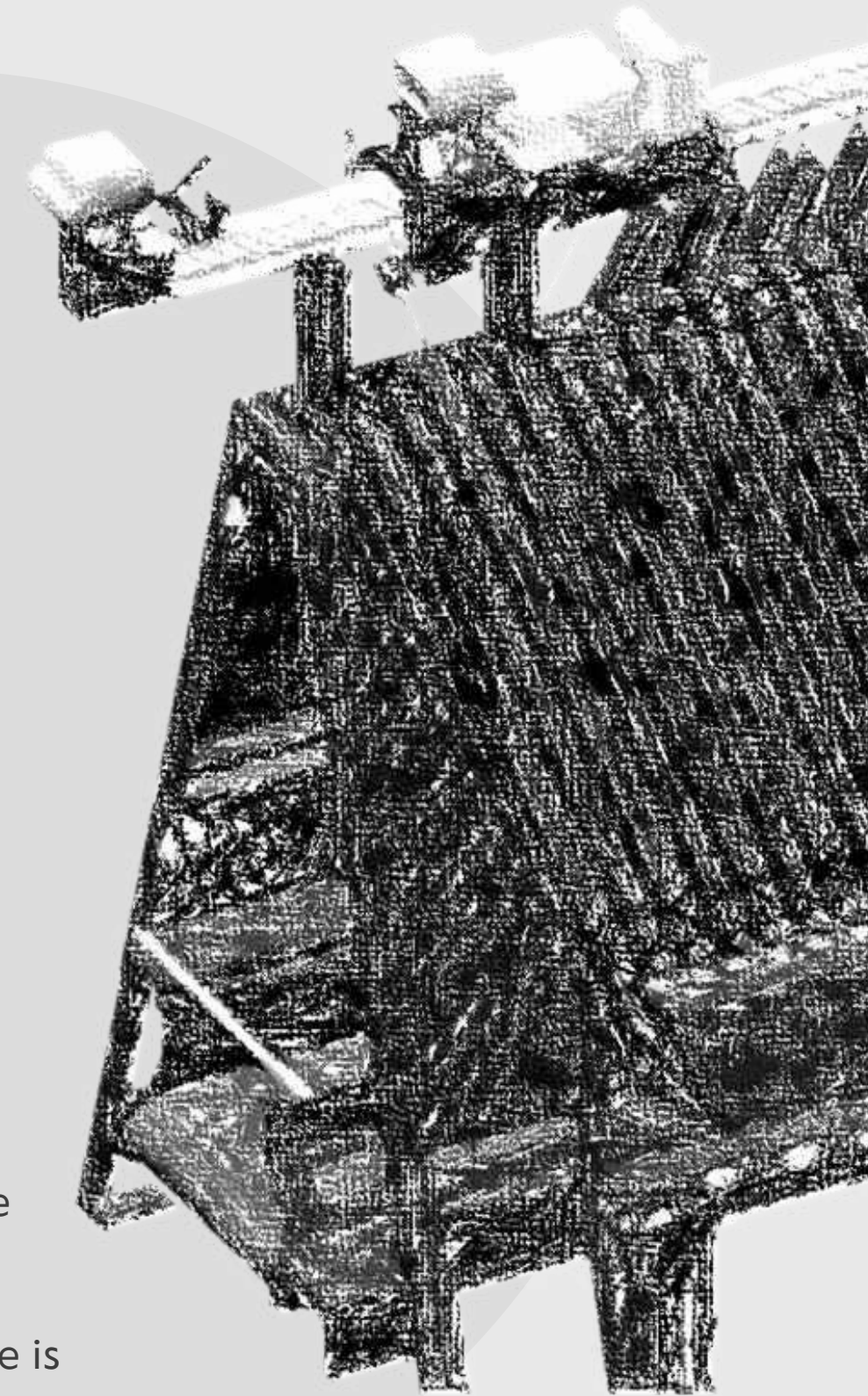
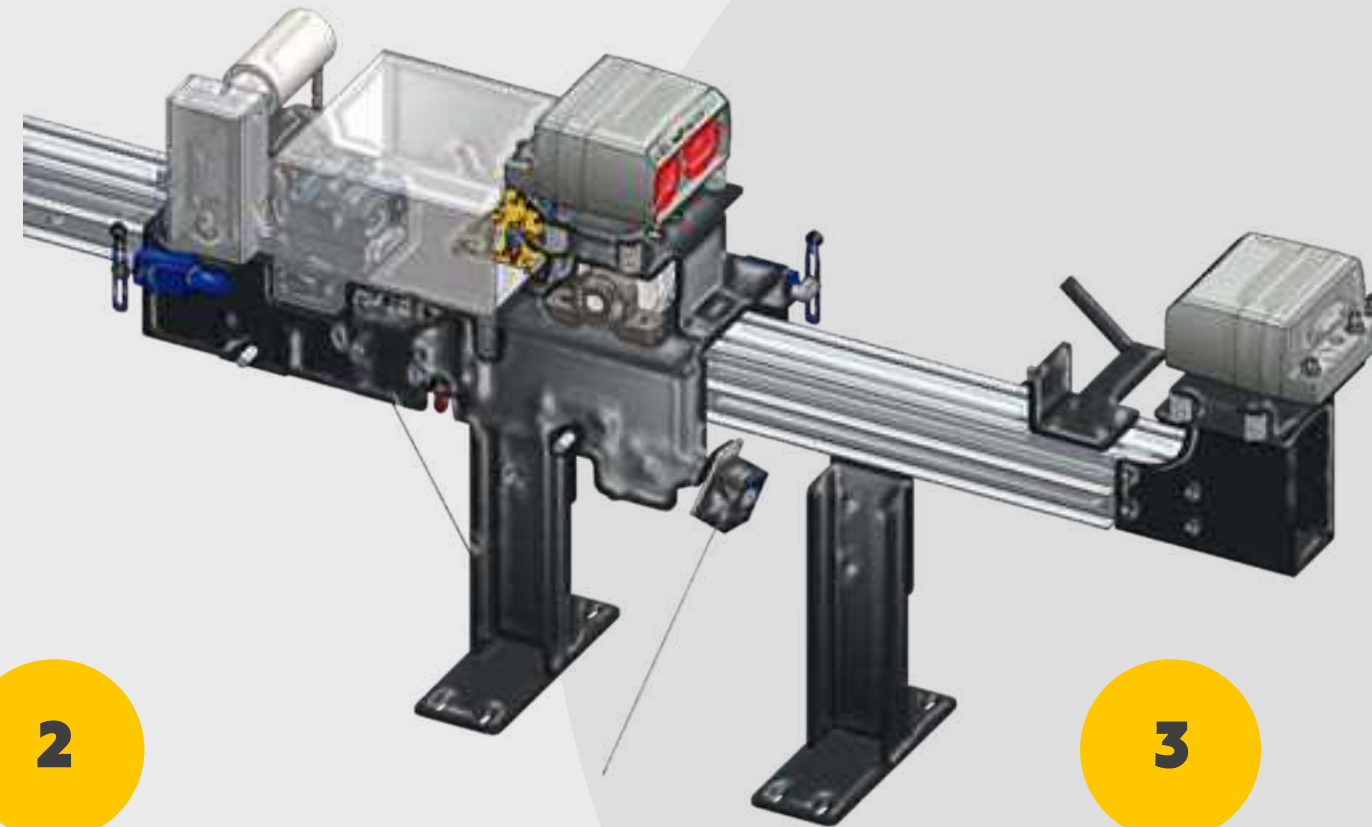
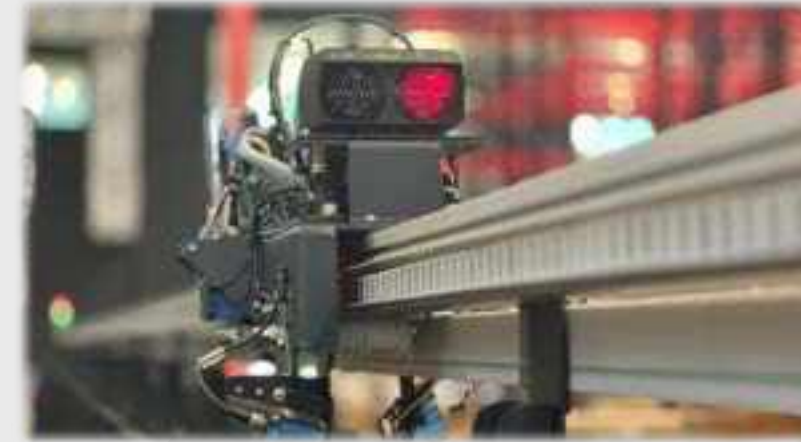

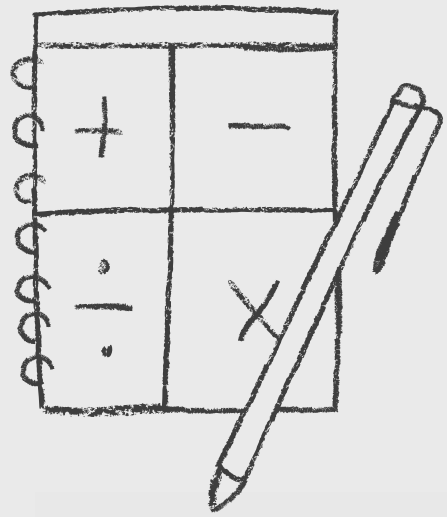

# PTL Pick To Light

## Fast and Visually Assisted Handling

Pick To Light is considered the fastest (manual) picking method available for order fulfillment operations. Used in a wide range of picking and sorting scenarios, Pick To Light solutions guide their operators through different logistics and also production processes all over the world.

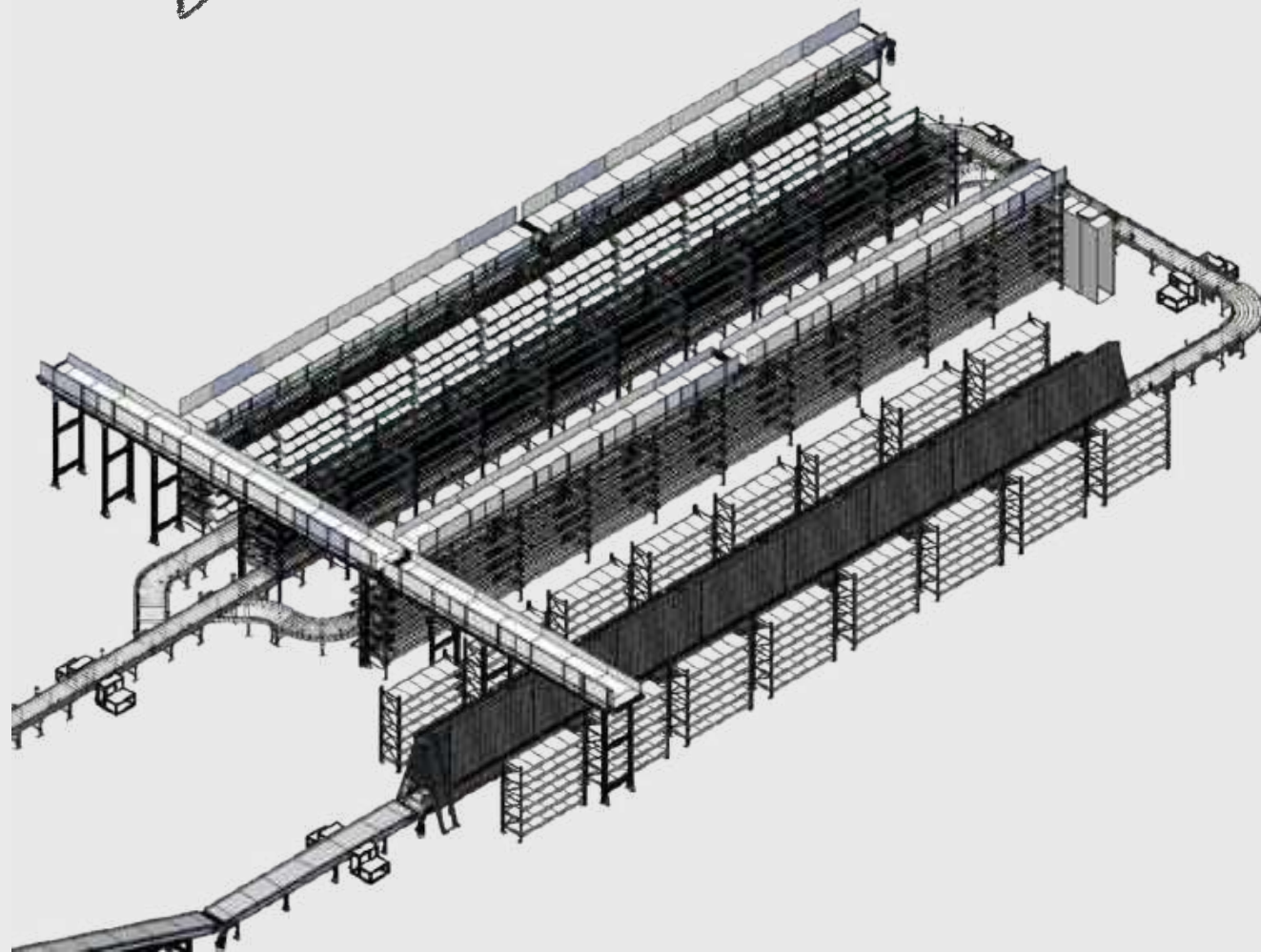

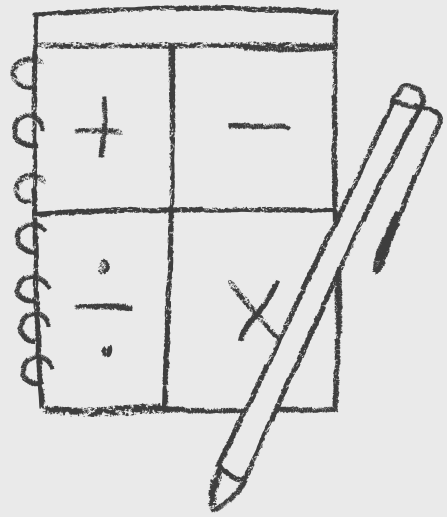

# PTL Pick To Light

High Quality

Simplify Warehouse Management and Picking Operations with Pick To Light System. Benefit from our cost-effective and fast deployment solutions for various problems in different sectors.

1

The operator is guided to the relevant position via an LED display, which also shows the quantity to be processed. This method eliminates the need to search for a position and leads to increased efficiency and accuracy. Prode's proven PTL technology now has references in many different industries such as nutrition, retail, pharmaceuticals, cosmetics, automotive and many others.

2

PTL is a paperless picking system for picking products from storage positions to fulfill an order.

3

### Quick Commissioning

It facilitates the picking of fast-moving goods, often from flow racks. Each storage location is equipped with a picking light that indicates from where and how many pieces to pick. At the workstation at the head of the line, the barcode of a specific order (case, carton, box, etc.) is captured with a scanner. Lights come on at these locations where products need to be picked. The display shows how many products need to be collected. The operator presses the confirm button to validate the picking instruction.

# PTL Pick To Light Equipment

The high-quality PTL devices have an ergonomic design and are very robust. To achieve an interference-free data flow, the PTL devices are mounted on a robust aluminum rail. Thanks to its design, dust deposition on and inside these devices is prevented. The rail is firmly mounted on the rack and can be bonded across multiple scanning angles. The amount to be collected is shown on a 3- to 5-digit display. The multicolor confirmation button lights up to indicate the position and is also used for confirmation. The amount can be adjusted for correction with the plus (+) and minus (-) buttons. Each PTL device has a software coded designation. Optionally the numbers can be applied alphanumerically.



# Narrow Belt Sorter

- High speed sorting system.
- Error-free separation process thanks to specially prepared narrow belts.
- Advantage of flexible design that can be manufactured in one piece from 5 meters to 100 meters.
- Average of 9.000 product separation per hour.
- Can operate without personnel.
- Artificial intelligence supported.
- Can provide reporting.

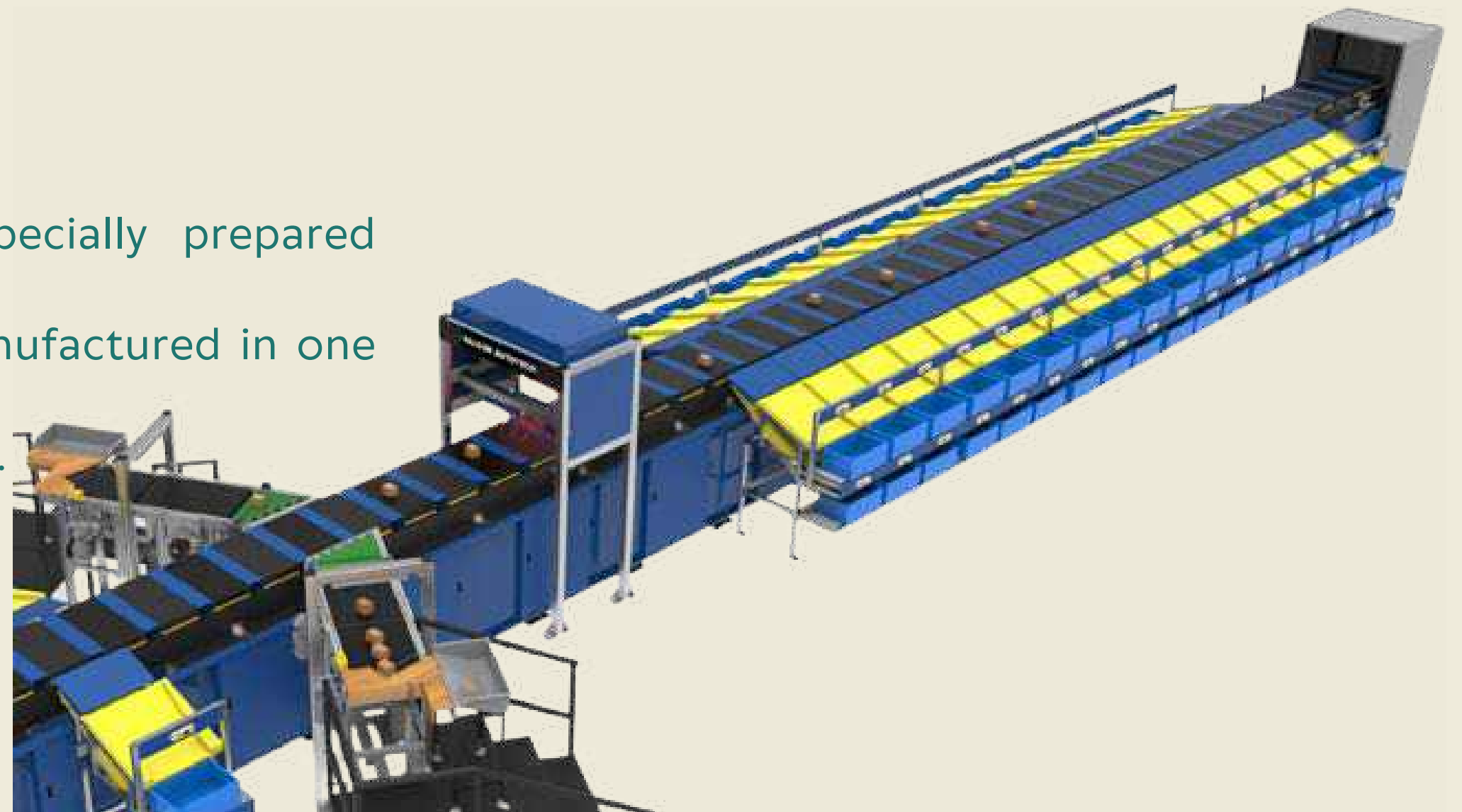

# Narrow Belt Sorter

- Ability to process packages between 50gr-13kg.
- +/-20gr precision
- 5mm measurement accuracy





# Our Solutions



## SMART AND AUTONOMOUS WAREHOUSE

Autonomous warehouses, e-commerce warehouses, heavy and light shipment warehouses. 20000/hour capacity cargo distribution centers, 20000/day e-commerce distribution centers.



## T-PICK

High speed picking system: 1800 orders per hour (45000 products in total) picking capacity, functioning without personnel, 0.3-0.8% error rate, high-tech, easy operation, full integration with the customer, multiple integration with many e-commerce servers.



## NARROW BELT SORTER

Cargo sorting up to 9000 pieces per hour, ability to operate at high speeds, 24 hours operation capacity, ability to work with all packages in the range of 0-5 volumetric weight, ability to handle packages between 50gr-13kg, Ability to work with minimum personnel, low error rate.



## CROSSBELT SORTER

Sorting up to 6000 parcels per hour, low personnel requirements, low error rate, effective and easy to use.



## CONVEYOR SYSTEMS

Cost-effective and long-lasting conveyors, ease of installation and maintenance



## DIVERTER SORTER

4500 parcels per hour sorting capacity, low error rates, maintenance free.

**ProdeUSA**  
Warehouse Solutions

# CONVEYOR SYSTEMS

[www.usaprode.com](http://www.usaprode.com)

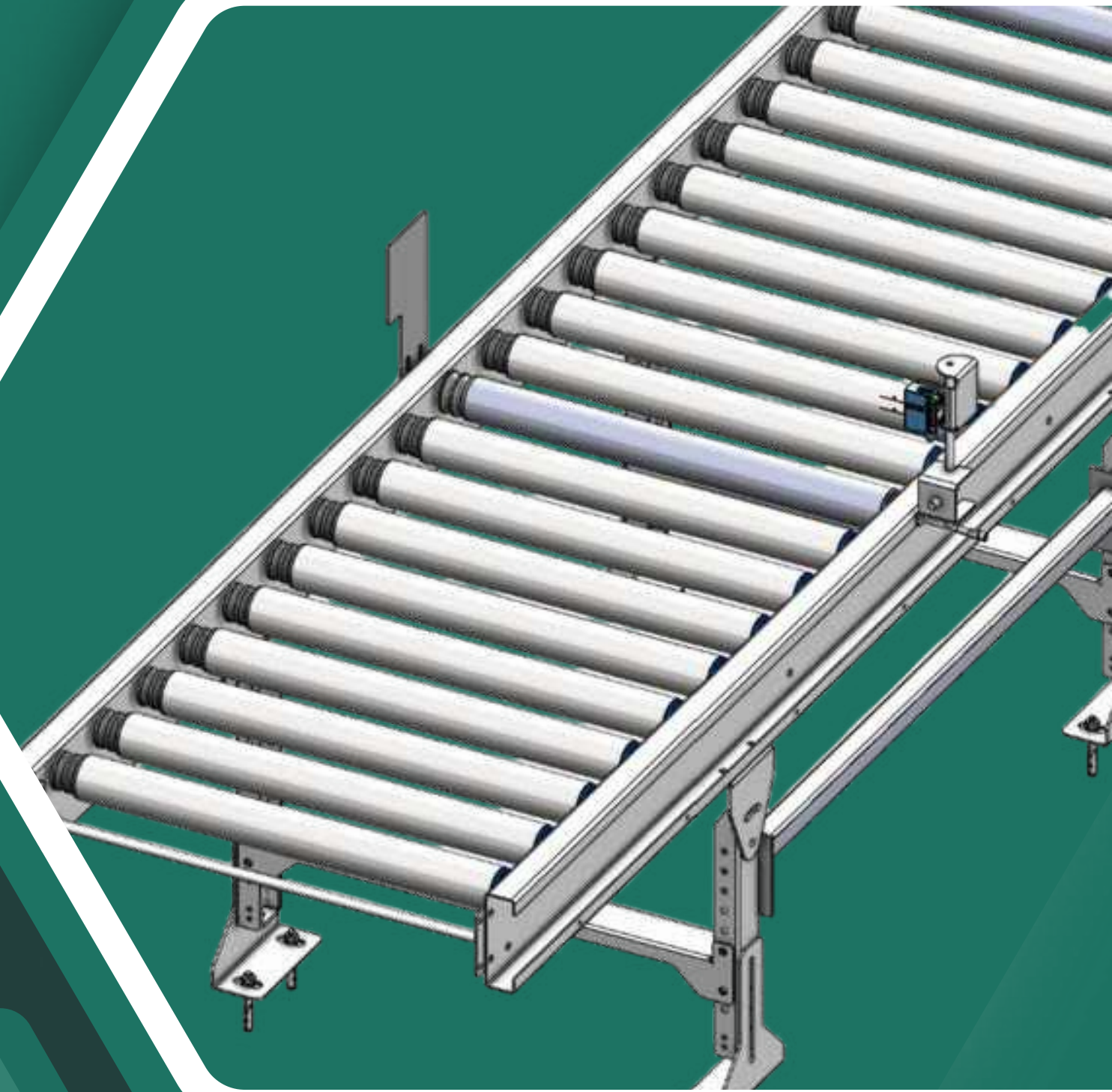

**T-Pick**  
Automatic Picking System

The intelligent and flexible modules are available in various widths and are suitable for the transportation of all goods commonly used in intralogistics. PRODE offers you a functional conveyor system with professional and thoughtful advice, rather than simply being a 'module dealer'.

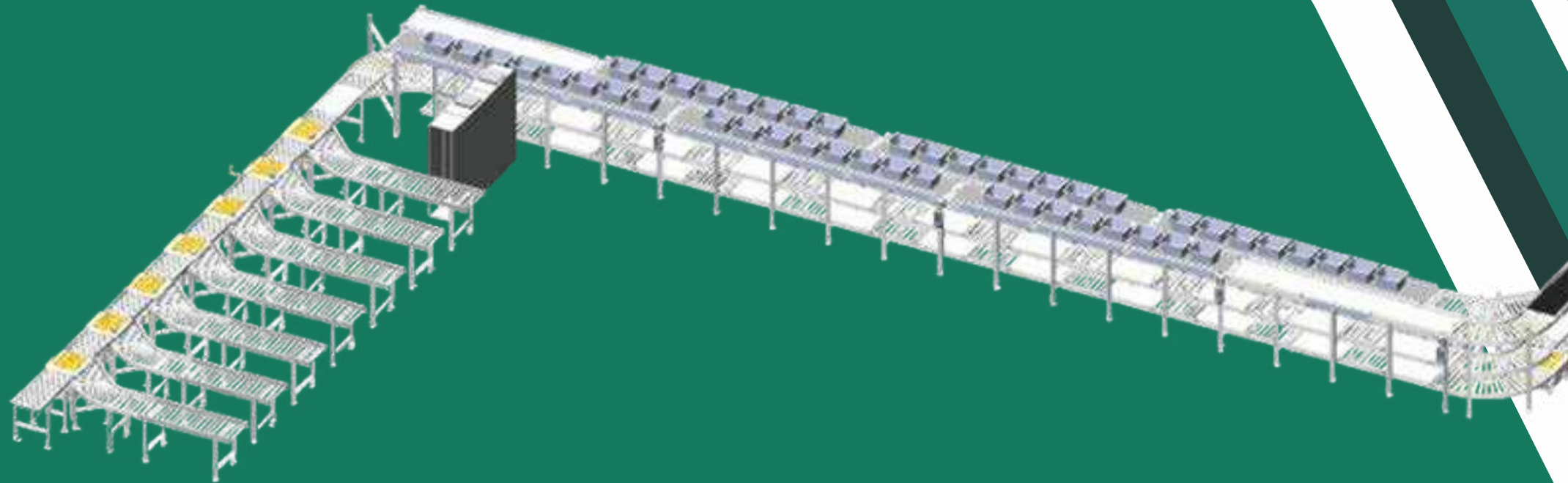

PRODE Conveyors and equipment are unique due to their short installation and commissioning time. All components (both mechanical and electrical) come pre-assembled in our modules, including wiring and correct E-plan codes. The smart and flexible modules have available widths in various colors and are suitable for handling all common goods in intralogistics.



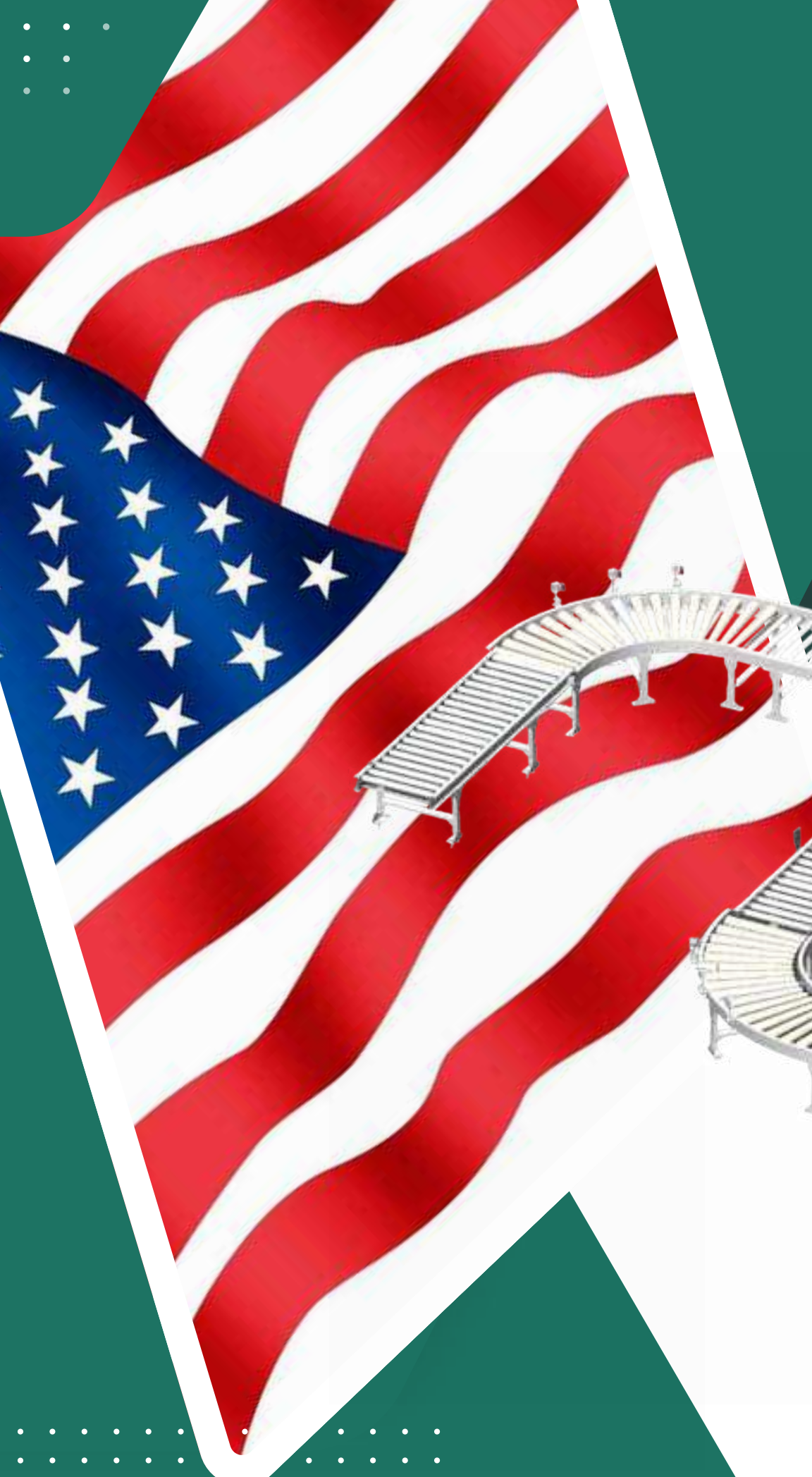

## ▶ MODULAR

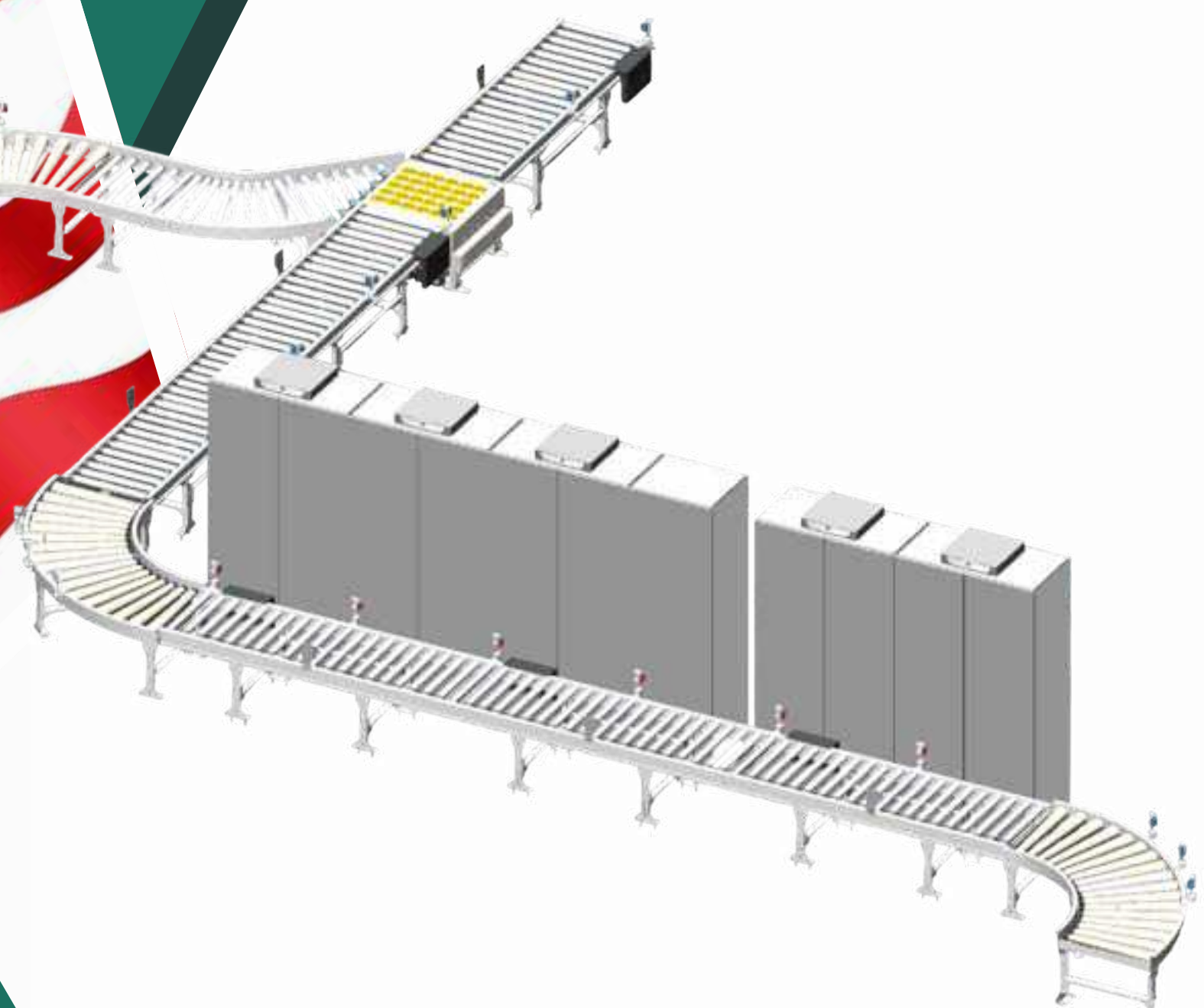

PRODE's conveyor systems ensure a healthy and fast flow of goods. Benefit from our expertise and know-how, gained through numerous international projects, in the consultation, planning and realization of a conveyor system for the in-house handling of small load carriers.

For the handling of hoppers, cartons, trays or loads, PRODE provides you with everything from the control unit to the conveyor system from a single source. Meanwhile, the high compatibility of all our components ensures the smooth flow of the complete system. Conveying, sorting, inward and outward transfer, storage and accumulation - there is no limit to our solutions for the in-house handling of small load carriers, as well as for tasks in intralogistics.

Our difference from other vendors is that we manufacture the conveyor system parts ourselves.



# DESIGN

## 90 Degree Roller Conveyor

- It moves materials continuously using a programmed controller.
- Each section is driven by a motor that propels the pulleys by means of a belt.
- Completely modular
- Integrated and labeled wiring.
- Fast installation time.



# DESIGN

## 45 Degree Roller Conveyor

- Assembles materials from two different conveying lines by directing them onto one line.
- It can also be used as an exit path to send materials to the left or right according to the material flow.
- Completely modular
- Integrated and labeled wiring.
- Fast installation time.



# PASS THROUGH CONVEYOR

- Used for material transportation and passage of personnel.
- Thanks to the switch on it, it cuts the power on it for safety the moment it is released.
- The hinged part can be opened up to 90 degrees.
- Continues to work from the moment it was switched off once it resumes.
- Completely modular
- Integrated and labeled wiring.
- Fast installation time.



## Safe

Essential for a smooth flow of goods and safe personnel evacuation

## Ergonomic

Easy Installation  
Modular  
Integrated Safety Measures



# CONVEYOR IDLER

- All rollers are mobile and adjustable in size.
- All measurements can be customized according to your needs.
- Height can be adjusted after installation.
- It can be manufactured from steel or aluminum frames.
- Completely modular
- Integrated and labeled wiring.
- Fast installation time.

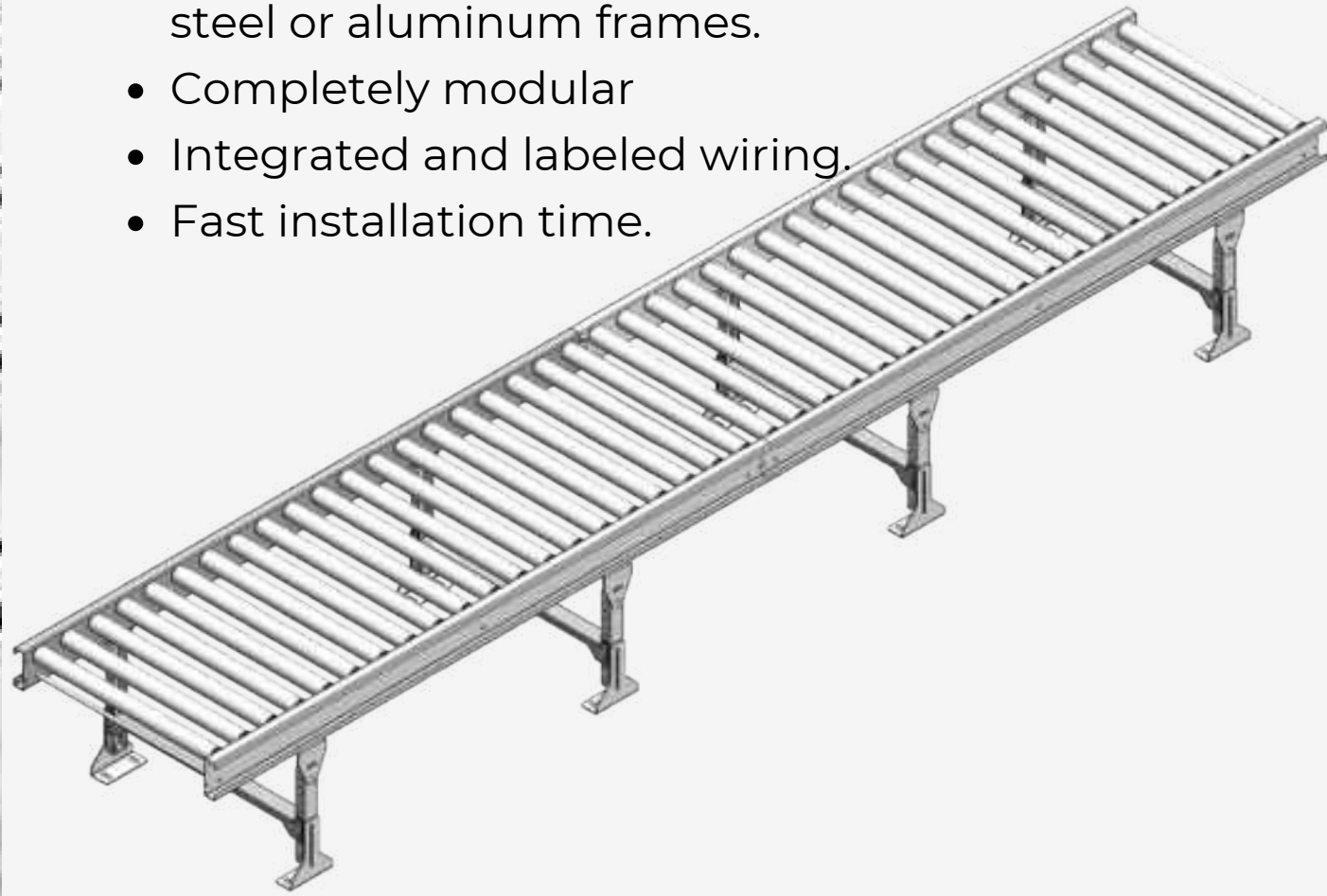

# MOTOR DRIVEN

- It provides movement by transmitting the drive power from the 24V motor to other idler rolls.
- All measurements can be customized according to your needs.
- Height can be adjusted after installation.
- It can be manufactured from steel or aluminum frames.
- Completely modular
- Integrated and labeled wiring.
- Fast installation time.







## ▶ PVC CONVEYOR BELT

- Transports materials using a powered conveyor belt.-With this module it is possible to descend the materials from a raised level.
- Completely modular
- Integrated and labeled wiring.
- Fast installation time.



# **SORTER**

the best address for technology and speed

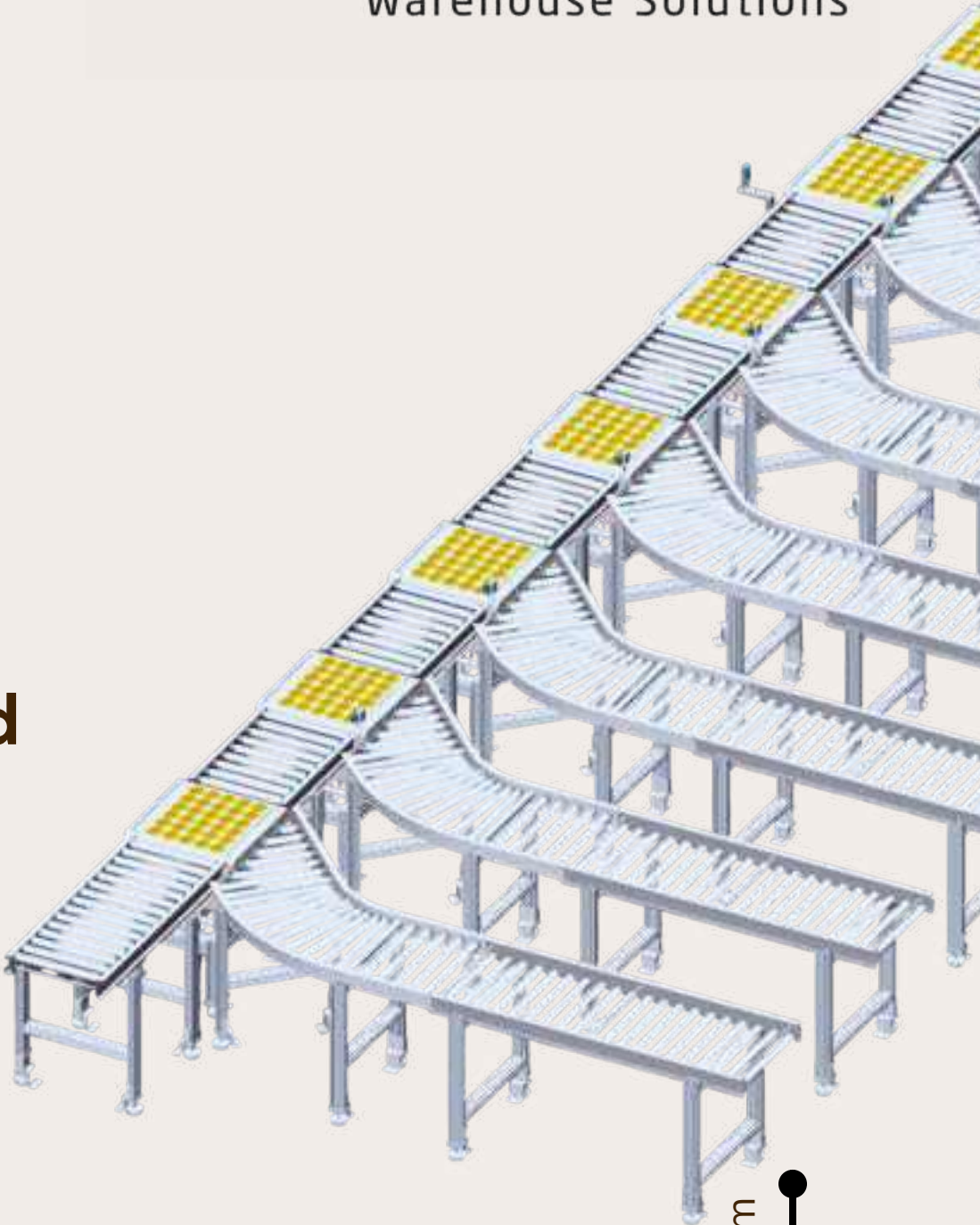



# **SORTER**

**the best address for technology and speed**

**ProdeUSA**  
Warehouse Solutions

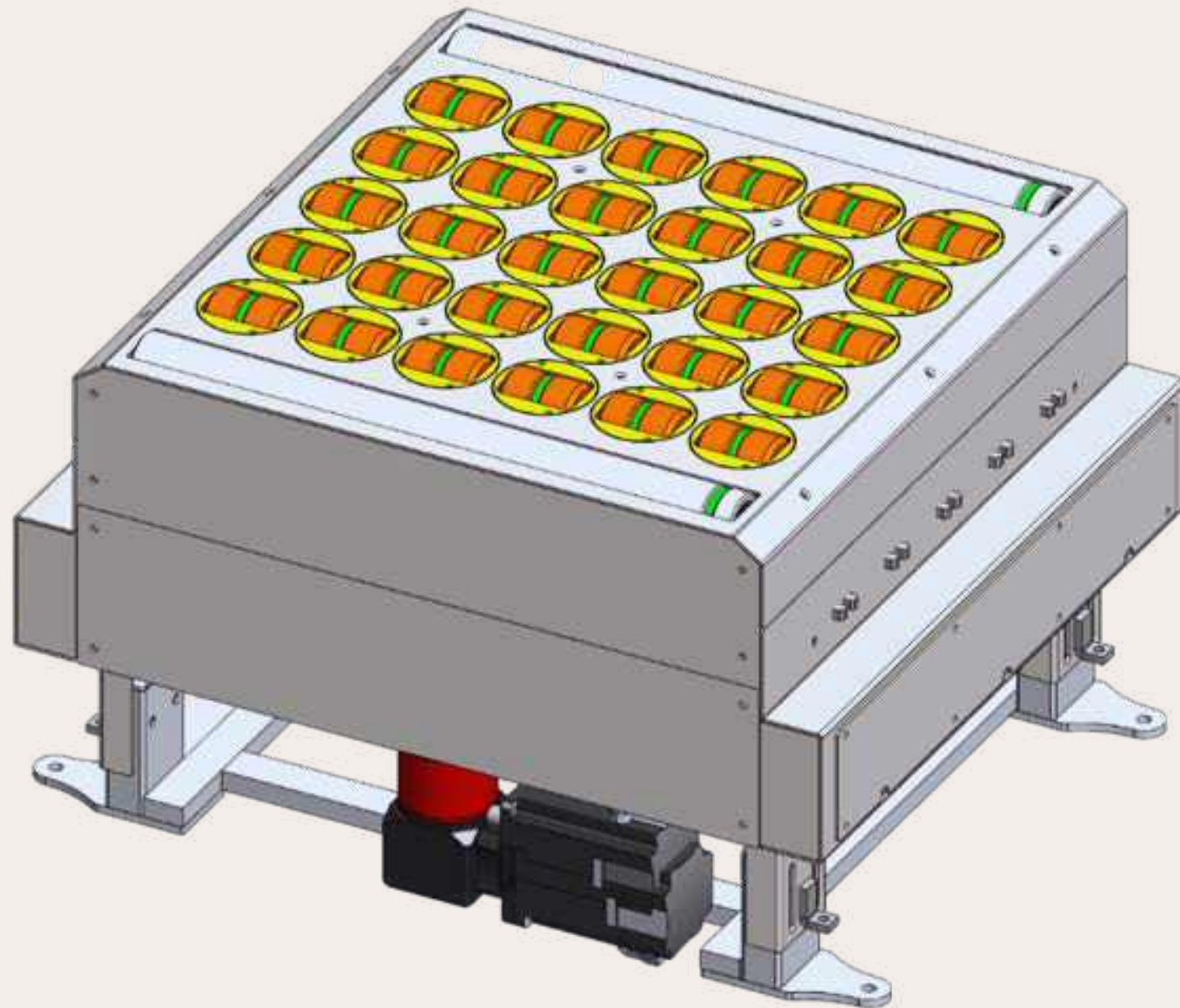

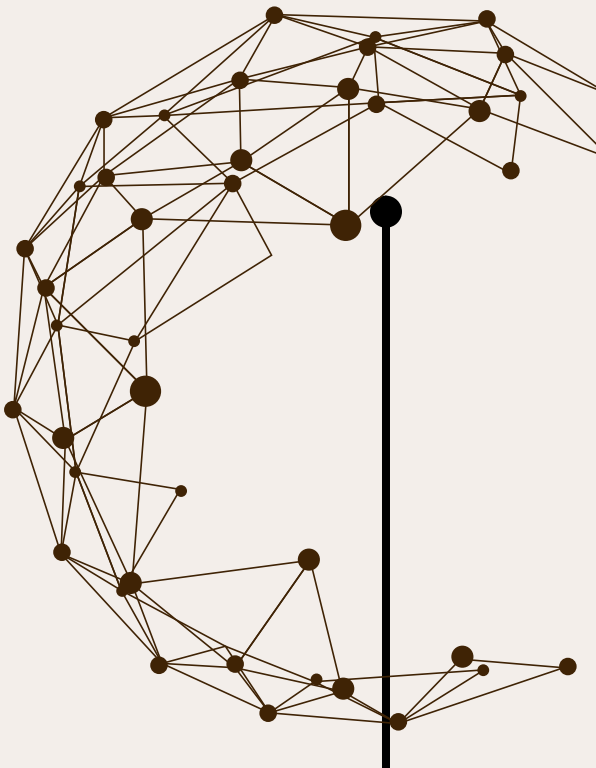
- The modular setup of our equipment is unique due to their short installation and deployment time.
  - All components (both mechanical and electrical) come pre-assembled with our modules, including wiring and correct E-plan codes.
  - The smart and flexible modules have available widths in various colors and are suitable for handling all prevalent goods in intralogistics.
  - The operational capacity can be adjusted according to demand and can be custom-built.
- 

# SHUTTLE SYSTEMS



- The four-directional vehicle is mainly used for automatic transportation of palletized goods in the warehouse. It is an intelligent storage equipment integrating smart control, automatic operation, personnel-free decision-making and other functions.
- The four-directional vehicle can automatically perform inventory and picking, smart leveling, automatic climbing, automatic lane and layer change, and can also reach any position of the warehouse according to customer needs, so that the warehouse space utilization rate can be maximized.

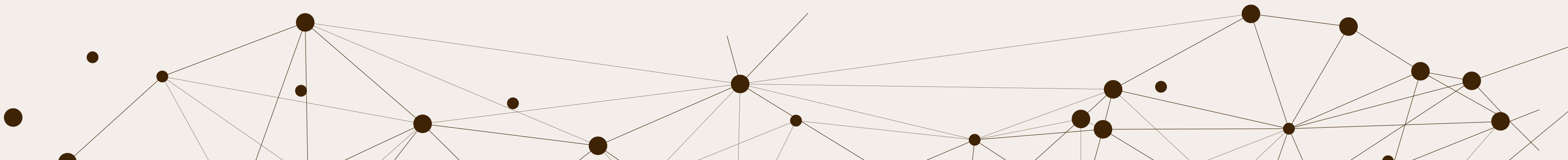

# SHUTTLE SYSTEMS

- Shuttle systems use robotic transport vehicles that can move horizontally along the warehouse shelves.
- Each shuttle has a customizable structure with a platform that carries materials and is equipped with sensors.
- Major Distribution Centers: Ideal for storing and retrieving large volumes of materials.
- Cold Storage Centers: Suitable for storing and transporting materials in low temperature environments.
- Automotive Industry: Used for the storage and shipment of automotive parts.

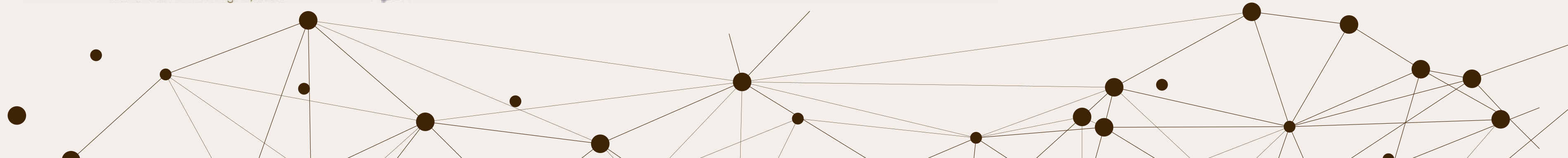

# SHUTTLE SYSTEMS



- The height of the four-directional shuttle cart is compact, and the distance between the upper surface of the rail of the cart and the ground is only 300mm, which can efficiently utilize the warehouse space.
- All equipments and control components of the 4-directional vehicle are very reliable and sophisticated. The operating system adopts simple and stable control elements, uses special algorithms, and combines the simple and solid mechanical structure of the cart to achieve the purpose of stable, accurate, fast and reliable operation of the vehicle.
- The utilization of the four-directional cart is flexible and adjustable. If there is demand for performance growth, you only need to increase the number of four-directional shuttle carts, and the workload of such additional project transformation will be very small, or even zero
- The project investment is low and the equipment quantity is geared to the output demanded by the customer. While meeting the customer's demand for efficiency, the investment costs can be reduced

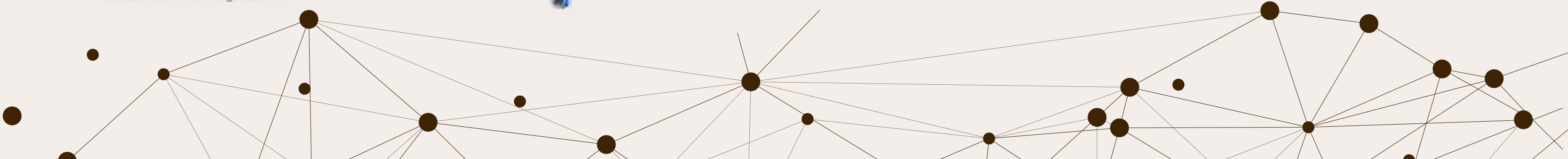

# PRODE WMS

WMS is a system designed to actively and efficiently manage all operations that can take place in a warehouse, to ensure that operations are completed paperless, in the fastest possible time, with the least amount of human and machine resources, without errors, to make decisions, to monitor the operations performed online and to present the data of the operations carried out in the form of reports.

WMS can be a stand-alone software or it can work as a tool of an ERP system. Since warehouse processes are linked to other processes of companies (finances, sales, etc.), WMS can work integrated with other programs used in those departments.

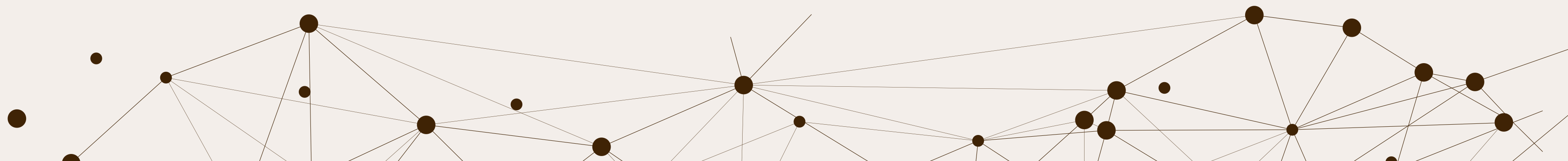

# WHY ProdeUSA

Warehouse Solutions



## AUTOMATION SOFTWARE

The software, automation and electronic engineering of all products and advanced technology systems are carried out by our teams of experts.

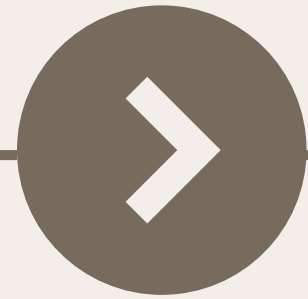

## TECHNICAL ASSISTANCE

24-hour software and mechanical technical assistance.

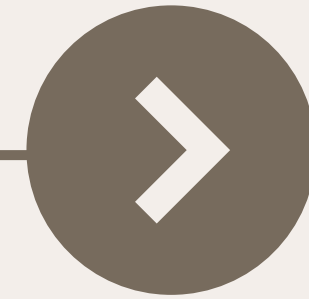

## SYSTEM ADVANTAGES

- Cost reduction of staff
- Low installation cost
- High rates of capacity increase
- Reduced operational costs.
- Simple operation and handling
- Instant technical support,
- Fast delivery and deployment

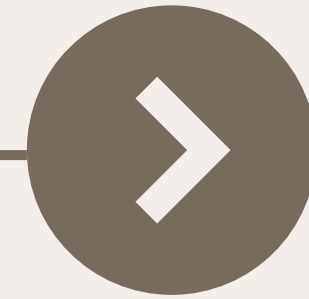

## ADVANTAGES

- Customer and product-specific design
- Local design and production
- Rapid technical assistance (software & mechanical) Significant savings in operational costs
- Much higher price/performance ratio compared to counterparts

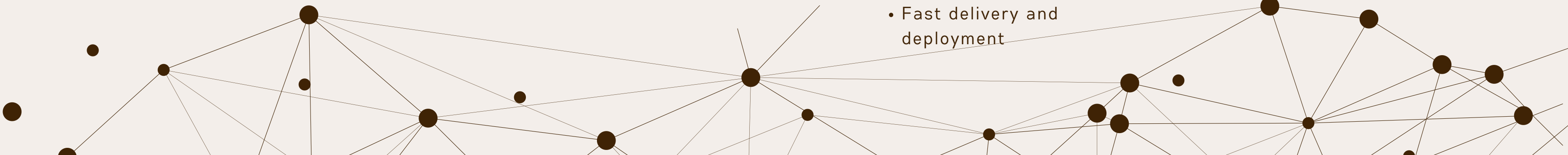



# OUR SECTORS

**ProdeUSA**  
Warehouse Solutions

**01** COSMETICS SECTOR

**02** E-COMMERCE WAREHOUSES

**03** LOGISTICS CENTERS

**04** PHARMACEUTICAL-HEALTH  
WAREHOUSES

**05** FULFILLMENT CENTERS

**06** CHAIN MARKET DISTRIBUTION  
CENTERS

**07** CARGO OPERATION CENTERS

**08** COLD STORAGE

**09** TEXTILE WAREHOUSES

**10** AUTOMOTIVE

**T-Pick**  
Automatic Picking System

As PRODE, our values have been defined and honored with the contributions of all of our team. Our values create a culture built on transparency, honesty, credibility and quality. This culture reinforces our responsibilities towards each other and the people and organizations we cooperate with.

We believe that we will protect these principles to the fullest and do our best. The value-based logistics culture we have created with these codes of ethics continuously strengthens the respect and trust we have earned in the eyes of all our stakeholders. We would like to thank you all for your efforts and support in creating this culture, which will be sustainable and permanent with our persisting ethical codes.

PRODE attaches great importance to occupational health and safety in all business activities.

Our attitude emphasizes the importance of individual differences, equality and respect.

A business like PRODE takes various measures to protect its physical assets. These include technological measures such as security cameras, alarm systems, access control, fire prevention and extinguishing systems.

PRODE's policies on the protection of company confidential information are very sensitive and these policies are strictly adhered to. Important information such as the company's trade secrets, intellectual property rights, marketing strategies are not to be revealed. Our employees are obliged to protect such information and also are bound not to use the information obtained from their former employers.

The use of technologies is an important issue in terms of privacy and security of personal data. When our employees access the company's computer network, they must keep their passwords strong and secure and take precautions against unauthorized access. It also ensures the confidentiality and security of any personal data shared with business partners, suppliers and other third parties. PRODE's employees share this data only with those with whom they will cooperate and take the necessary security measures.

PRODE does not accept the offer or solicitation of payments, services, gifts, hospitality or any other thing of value to improperly influence public officials or persons in the private sector in order to obtain business or commercial advantage. Making inappropriate payments through third parties is also not permitted.

**You can find our complete code of ethics on our website.**

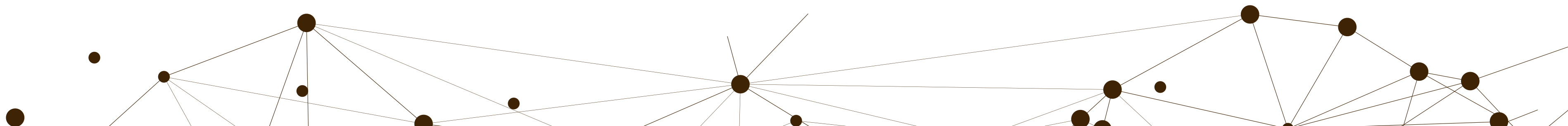

*Thank You*

# OUR REFERENCES

**ProdeUSA**  
Warehouse Solutions

**Prode**  
Design Engineering

**T-Pick**  
Automatic Picking System





# ProdeUSA

Warehouse Solutions

**Prode**  
Design Engineering

**T-Pick**  
Automatic Picking System

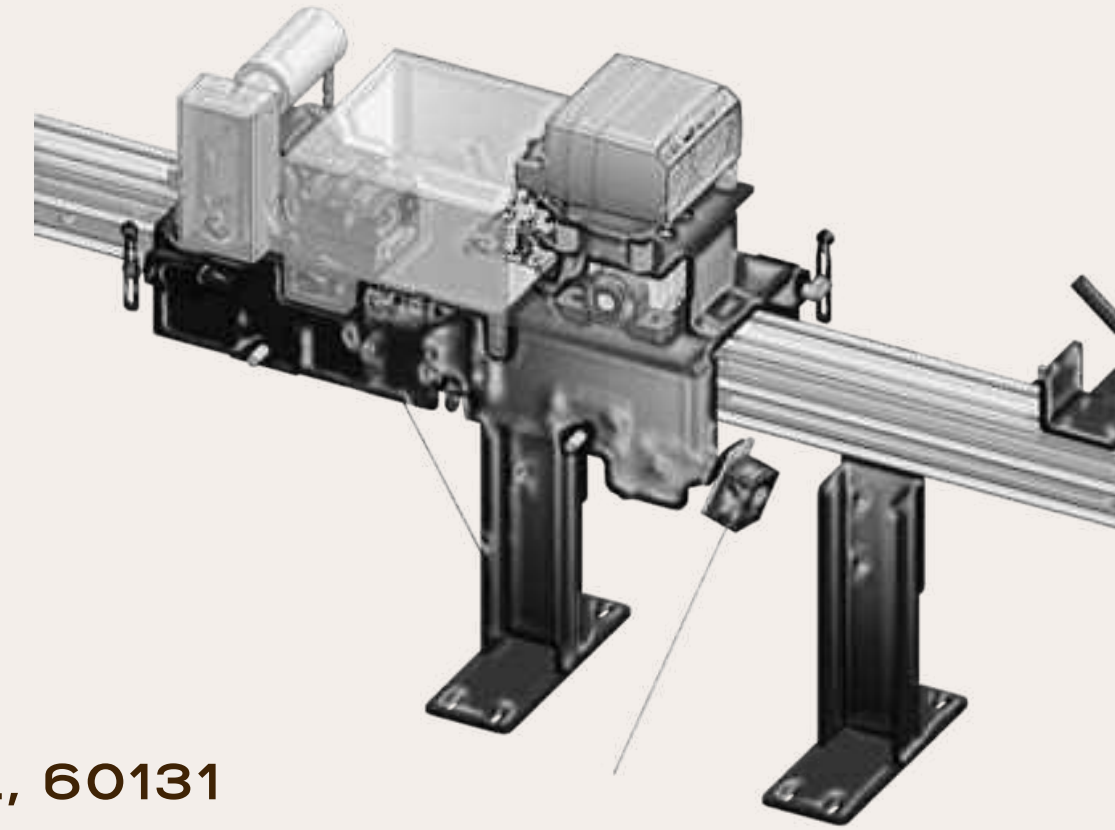

**FACTORY ADDRESS : Tavşanlı Mah. 4538 Sok. No:5/A Gebze/KOCAELİ**

**USA HQ : 11417 Irving Park Road (IL-19), Suite Number B-13-3, Franklin Park, IL, 60131**

